

TCVN 6305 – 3: 2007

ISO 6182-3: 2005

Second edition

**FIRE PROTECTION - AUTOMATIC SPRINKLER SYSTEMS -
PART 3: REQUIREMENTS AND TEST METHODS
FOR DRY PIPE VALVES**

(This English version is for reference only)

HA NOI - 2007

Foreword

TCVN 6305-3:2007 replaces TCVN 6305-3:1997 (ISO 6182-3:1993).

TCVN 6305-3:2007 was identical to ISO 6182-3:2005.

TCVN 6305-3:2007 was prepared by the Technical Committee TCVN/TC 21 *Fire protection equipments*, proposed by the Directorate for Standards, Metrology and Quality, issued by the Ministry of Science & Technology.

TCVN 6305 (ISO 6182:2004) consists of the 5 parts, under the general title Fire protection - Automatic sprinkler systems:

- TCVN 6305-1:2007 (ISO 6182-1:2004) - Part 1: Requirements and test methods for sprinklers;
- TCVN 6305-2:2007 (ISO 6182-2:2004)- Part 2: Requirements and test methods for wet alarm valves, retard chambers and water motor alarms;
- TCVN 6305-3:2007 (ISO 6182-3:2004)- Part 3: Requirements and test methods for dry pipe valves;
- TCVN 6305-7:2006 (ISO 6182-7:2004)- Part 7: Requirements and test methods for early suppression fast response (ESFR) sprinklers;
- TCVN 6305-11:2006 (ISO 6182-11:2004)- Part 11: Requirements and test methods for pipe hangers.

Fire protection - Automatic sprinkler systems - Part 3: Requirements and test methods for dry pipe valves

1 Scope

This standard specifies performance, requirements, methods of test and marking requirements, for dry pipe valves and manufacturers' specified relevant trim used in dry pipe automatic fire protection systems.

Performance and test requirements for other auxiliary components or attachments to dry pipe valves are not covered by this standard.

2 Normative references

The following referenced documents are indispensable for the application of this document. For dated references, only the edition cited applies. For undated references, the latest edition of the referenced document (including any amendments) applies.

TCVN 4509:2006 (ISO 37) Rubber, vulcanized or thermoplastic — Determination of tensile stress-strain properties.

TCVN 2229:2007 (ISO 188) Rubber, vulcanized or thermoplastic — Accelerated ageing and heat resistance tests

ISO 7-1, Pipe threads where pressure-tight joints are made on the threads — Part 1: Dimensions, tolerances, and designation

TCVN 6305-3: 2007

ISO 898-1, Mechanical properties of fasteners made of carbon steel and alloy steel — Part 1: Bolts, screws and studs

ISO 898-2, Mechanical properties of fasteners - Part 2: Nuts with specified proof load values - Coarse thread

3 Terms and definitions

For the purposes of this document, the following terms and definitions apply.

3.1 Alarm device

Mechanical or electrical device to sound an alarm upon operation of the valve

3.2 Automatic drain valve

Normally open device that automatically drains water from and vents the intermediate chamber of a valve to the atmosphere when the valve is in the ready position, and limits water flow from the chamber after the valve has tripped

3.3 Clapper

Type of sealing element

NOTE: See also 3.17.

3.4 Corrosion-resistant material

Metallic material of bronze, brass, Monel¹ metal, austenitic stainless steel, or equivalent, or plastic material conforming with the requirements of this document

3.5 Differential

Ratio of service pressure to system air pressure (expressed as gauge pressures) at the trip point

NOTE: See also 3.23.

¹) Monel is an example of a suitable product available commercially. This information is given for the convenience of users of this standard and does not constitute the content of product standard.

3.6 Differential-type valve

Type of valve in which air pressure in the system acts directly and/or indirectly on the sealing assembly to maintain it in the closed position

NOTE: The air seat of the sealing assembly is of equal or larger diameter than the diameter of the water seat of the sealing assembly, with the two separated by an intermediate chamber maintained at atmospheric pressure.

3.7 Dry pipe system

Automatic fire protection system in which the piping contains air or nitrogen under pressure, the release of which allows water from a water supply to discharge through the system

3.8 Dry pipe valve

Valve that controls the flow of water into a dry pipe sprinkler system and incorporates provision for actuation of an alarm under specified conditions

3.9 Flow velocity

Speed of water flow through a valve expressed as the equivalent water velocity through a pipe of the same nominal size as the valve

3.10 Intermediate chamber

That part of a valve which separates the air and/or water sealing assembly seating surfaces and is at atmospheric pressure when the valve is in the ready condition

3.11 Leak point

System air pressure for a specific service pressure at which water begins to flow from the intermediate chamber, automatic drain valve or alarm connection

3.12 Mechanical-type valve

Type of valve in which the air pressure in the system acts on the sealing assembly and linking mechanism to maintain it in the closed position

3.13 Priming water

Water used to seal a sealing assembly and prevent cementation of working parts

TCVN 6305-3: 2007

3.14 Rated working pressure

Maximum service pressure at which a valve or retard chamber is intended to operate

3.15 Ready (set) condition

State of a valve with the sealing assembly in the closed or set position with service and system pressure applied

3.16 Reinforced elastomeric element

Element of clapper, clapper assembly or seat seals in a composite of an elastomeric compound with one or more other components

3.17 Sealing assembly

Main movable sealing element (such as a clapper) of the valve which prevents the reverse flow of water and which maintains air pressure in the system piping

3.18 Sealing assembly seat ring

Main fixed sealing element of a valve which prevents the reverse flow of water and which maintains air pressure in the system piping

3.19 Service pressure

Static water pressure at the inlet to a valve when the valve is in the ready condition

3.20 System pressure

Static water pressure at the main outlet of a valve when the valve is in the ready condition

3.21 System air pressure

Static air pressure in the system piping when the valve is in the ready condition

3.22 Trim

External equipment and pipework, excluding the main installation pipework, fitted to valve installation assembly

3.23 Trip point

Point at which a valve operates, admitting water into the system, measured in terms of the system air pressure at a given service pressure

3.24 Water motor alarm

Hydraulically actuated device which provides a local audible alarm as a result of a flow through a valve

3.25 Water motor transmitter

Hydraulically actuated device which generates an electrical current for a remote alarm as a result of operation of the valve

4 Requirements

4.1 Nominal sizes

The nominal size of a valve shall be the nominal diameter of the inlet and outlet connections, i.e. the pipe size for which the connections are intended. Sizes shall be 40 mm, 50 mm, 65 mm, 80 mm, 100 mm, 125 mm, 150 mm, 200 mm, 250 mm or 300 mm. The diameter of the waterway through the sealing assembly seat ring may be less than the nominal size.

4.2 Connections

4.2.1 All connections shall have been designed for use at the rated working pressure of the valve.

4.2.2 The dimensions of all connections shall conform with the applicable requirements of National standards or the equivalent International Standards.

4.2.3 An opening not smaller than 15 mm nominal diameter shall be provided for an alarm line connection.

4.2.4 If priming water is required to seal the downstream side of the sealing assembly, an external means shall be provided to introduce the priming water.

4.2.5 Means shall be provided to prevent water columning and to check the level of priming water.

4.2.6 Suitable means shall be provided to facilitate testing of alarms without tripping the valve.

TCVN 6305-3: 2007

4.2.7 Valves shall be provided with a means of sounding an alarm if water enters the downstream piping to an elevation exceeding 0,5 m above the sealing assembly, unless the valve is provided with an automatic means for drainage.

4.2.8 For differential-type valves, suitable means shall be provided to vent water from the intermediate chamber and to prevent a partial vacuum between the upstream and downstream sealing elements of the sealing assembly.

4.3 Rated working pressure

4.3.1 The rated working pressure shall be not less than 1,2 MPa (12 bar).

4.3.2 Inlet and outlet connections shall be permitted to be machined for lower working pressures to match installation equipment provided the valve is marked with the lower working pressure. See 7.3 f).

4.4 Bodies and covers

4.4.1 The body and cover shall be made of a material having corrosion resistance at least equivalent to cast iron.

4.4.2 Cover fasteners shall be made of steel, stainless steel, titanium, or other materials with equivalent physical and mechanical properties.

4.4.3 If non-metallic materials other than gaskets and seals or metals with a melting point less than 800 °C form part of the body or cover, the valve assembly shall be subjected to a fire exposure test, as specified in 6.8. Following the fire exposure test, the sealing assembly shall open freely and fully and the valve shall withstand a hydrostatic pressure test, as specified in 6.8.1, without permanent deformation or failure.

4.4.4 It shall not be possible to assemble the valve with the cover plate in a position which either improperly indicates flow direction or prevents proper operation of the valve.

4.5 Strength

4.5.1 An assembled valve, with the sealing assembly blocked open, shall withstand, without rupture, an internal hydrostatic pressure of four times the rated working pressure for a period of 5 min, when tested as specified in 6.9.

4.5.2 If the test in accordance with 6.9 is not done with standard production fasteners, the supplier shall provide documentation showing that the calculated design load of any fastener, neglecting the force

required to compress the gasket, shall not exceed the minimum tensile strength specified in ISO 898-1 and ISO 898-2, when the valve is pressurized to four times the rated working pressure. The area of the application of pressure shall be calculated as follows:

- a) If a full-face gasket is used, the area of application of pressure is that extending out to a line defined by the inner edge of the bolts.
- b) If an “O”-ring seal or ring gasket is used, the area of application of force is that extending out to the center line of the “O”-ring or gasket.

4.6 Access for maintenance

Means shall be provided to permit access to working parts and removal of the sealing assembly. Any method adopted should permit ready maintenance by one person with a minimum of down time.

4.7 Components

4.7.1 Any component which may normally be disassembled during servicing shall be designed so that it can not be reassembled improperly without providing an external visual indication, when the valve is returned to service.

4.7.2 With the exception of valve seats, all parts intended for field replacement shall be capable of being disassembled and reassembled using tools normally employed by the trade.

4.7.3 All components shall be non-detachable during normal operation of the valve.

4.7.4 Failure of the sealing assembly diaphragms or seals shall not prevent the valve from opening.

4.7.5 Sealing surfaces of sealing assemblies shall have corrosion resistance equivalent to bronze and have sufficient width of surface contact to withstand ordinary wear and tear, rough usage, compression stresses and damage due to pipe scale or foreign matter carried by the water.

4.7.6 Springs and diaphragms shall not fracture or rupture during 5 000 cycles of normal operation, when tested in accordance with 6.2.

4.7.7 There shall be no sign, on visual examination, of damage to the sealing assembly after testing for the operational requirements of 4.14 in accordance with 6.11 and 6.12.

TCVN 6305-3: 2007

4.7.8 When wide open, the sealing assembly shall bear against a definite stop. The point of contact shall be located so that impact or the reaction of the water will not permanently twist, bend or fracture valve parts.

4.7.9 Where rotation or sliding motion is required, the part or its bearing shall be made of a corrosion resistant material. Materials lacking corrosion resistance shall be fitted with bushings, inserts or other parts made of corrosion resistant materials at those points where freedom of movement is required.

4.7.10 A valve having a differential of the sealing assembly exceeding 1,16 to 1 for a service pressure range of 0,14 to 1,2 MPa (1,4 bar to 12 bar) shall be provided with an anti-seat latch that prevents the valve from resetting automatically. The valve shall require manual means to return the valve to the ready (set) condition. It shall not be possible to return the valve to the ready (set) condition before draining the pipe work.

4.7.11 A valve having a differential of 1,16 to 1 or less over a service pressure range of 0,14 MPa to 1,2 MPa (1,4 bar to 12 bar) shall be provided with means to prevent the valve from automatically returning to the ready (set) condition and to permit draining of the pipework after the valve has tripped. Manual or external means shall be provided to return the valve to the ready (set) condition.

4.8 Leakage

4.8.1 There shall be no leakage, permanent distortion or rupture of a valve, when an internal pressure of twice the rated working pressure is applied for 5 min with the sealing assembly open in accordance with 6.8.1.

4.8.2 No leakage shall be permitted across the sealing assembly into the intermediate chamber or into the alarm port, when tested in accordance with 6.8.2. There shall be no leakage, permanent distortion or rupture of a valve at an internal pressure of twice the rated working pressure applied to the upstream side of the sealing assembly for 2 h with the downstream end pressurized in accordance with 6.8.2

4.8.3 Mechanical type valves shall show no signs of leakage, permanent distortion or structural failure when subjected to an internal hydrostatic pressure of twice the rated working pressure applied for a period of 2 h to the upstream end of the valve with the sealing assembly closed and the downstream end vented in accordance with 6.8.3. Following this test, the valve shall operate in accordance with 4.14, when tested once in accordance with 6.11.2 at a service pressure of 0,2 MPa (2 bar).

4.8.4 Valves fitted with a latch shall withstand, without leakage, permanent distortion or structural failure, an internal hydrostatic pressure of twice the maximum air pressure specified by the manufacturer

for a period of 5 minutes applied to the downstream side of the valve with the sealing assembly closed and the upstream end vented in accordance with 6.8.4. Following this test, the valve shall operate in accordance with 4.14, when tested once in accordance with 6.11.2 at a service pressure of 0,2 MPa (2 bar).

4.8.5 Valves not fitted with a latch shall withstand, without leakage, permanent distortion or structural failure, an internal hydrostatic pressure of twice the rated working pressure for a period of 5 min applied to the downstream side of the valve with the sealing assembly closed and the upstream end vented in accordance with 6.8.4. Following this test, the valve shall operate in accordance with 4.14 when tested once in accordance with 6.11.2 at a service pressure of 0,2 MPa (2 bar).

4.9 Non-metallic components (excluding gaskets, seals and other elastomeric parts)

4.9.1 Non-metallic valve parts that affect proper valve function shall be subjected to the applicable ageing of its non-metallic parts as described in 6.4 and 6.5 using separate sets of samples, as applicable. After ageing, a valve shall meet the requirements of 4.8, 4.13 and 4.14.4, when tested in accordance with the applicable tests described in 6.6, 6.8 and 6.11.

4.9.2 There shall be no cracking, warping, creep, or other signs of deterioration which could preclude proper operation of the valve.

4.10 Sealing assembly elements

4.10.1 A seal made of elastomeric or other resilient materials shall not adhere to the mating surface when tested in accordance with 6.3.1. Where the same design of seat is used for more than one size of valve, it shall be permitted to only test the size with the highest stress on the seating surface.

4.10.2 Any non-reinforced elastomer forming the seal shall have the following properties, when tested in accordance with 6.3.2 and the appropriate sections of TCVN 4509:2006.

- a) maximum set of 5 mm when 25 mm long marks are stretched to 75 mm, held for 2 min, and measured 2 min after release;
- b) either:
 1. minimum tensile strength 10 MPa (100 bar) and minimum ultimate elongation 300 % (25 mm to 100 mm); or

TCVN 6305-3: 2007

2. minimum tensile strength 15 MPa (150 bar) and minimum ultimate elongation 200 % (25 mm to 75 mm);
- c) after exposure to oxygen for 96 h at $(70 \pm 1,5) ^\circ\text{C}$ and 2,0 MPa (20 bar), the tensile strength and ultimate elongation shall be not less than 70 % of the corresponding properties of specimens which have not been heated in oxygen, and any change in hardness shall not be greater than 5 type-A durometer units;
- d) after immersion in distilled water for 70 h at $(97,5 \pm 2,5) ^\circ\text{C}$, the tensile strength and ultimate elongation shall not be less than 70 % of the corresponding properties of specimens which have not been heated in water and the change in volume of the specimens shall be not greater than 20 %.

4.10.3 A reinforced elastomeric sealing element shall be capable of being flexed, without cracking or breaking, and shall have a change in volumetric expansion not greater than 20 % when tested in accordance with 6.3.3.

4.10.4 Sealing surfaces shall prevent leakage of water into the alarm port, when the valve is tested in the ready position in accordance with 6.10.

4.10.5 For a composite of an elastomeric compound with one or more other components, the tensile strength of the combination shall be at least twice that of the elastomeric material alone.

4.11 Clearances

4.11.1 The radial clearance between a hinged sealing assembly and the inside walls in every position except wide open shall not be less than 12 mm for cast iron bodies and shall not be less than 6 mm if the body and sealing assembly are of cast iron or steel with corrosion protective coatings tested in accordance with 6.14, non-ferrous material, stainless steel or materials having equivalent physical, mechanical and corrosion resistant properties. See Figure 1 a).

4.11.2 There shall be a diametrical clearance of not less than 6 mm between the inner edges of a seat ring and the metal parts of a hinged sealing assembly when the valve is in the closed position. See Figure 1 b).

4.11.3 Any space in which the sealing assembly can trap debris beyond the seat shall be not less than 3 mm deep.

4.11.4 The diametrical clearance ($D_2 - D_1$) between hinge pins and their bearings shall be not less than 0,125 mm. See Figure 1b).

4.11.5 The total axial clearance between the clapper hinge and adjacent valve body bearing surfaces shall be not less than 0,25 mm. See Figure 1 c).

4.11.6 Any reciprocating guide components, which are essential to allow a valve to open, shall have a minimum diametrical clearance of not less than 0,7 mm in that portion over which the moving component enters the fixed component and of not less than 0,05 mm in that portion of the moving component continuously in contact with the fixed component in the ready (set) position.

4.11.7 Sealing assembly guide bushings or hinge-pin bearings shall project a sufficient axial distance to maintain not less than 1,5 mm (clearance A) clearance between ferrous metal parts. See Figure 1. Clearance less than 1,5 mm shall be permitted where adjacent parts are of bronze, brass, Monel metal, austenitic stainless steel, titanium, or similar corrosion resistant materials. When corrosion resistance of steel parts is provided by a protective coating, the parts shall show no visible signs of deterioration of the coating such as blistering, delamination, flaking or increased resistance to movement when tested in accordance with 6.14.

4.11.8 If provided, a compensator shall be designed such that deposits or sediment will not readily accumulate to an extent sufficient to interfere with its proper operation. There shall be sufficient clearances between the working parts to allow proper sealing of the main and any auxiliary valves.

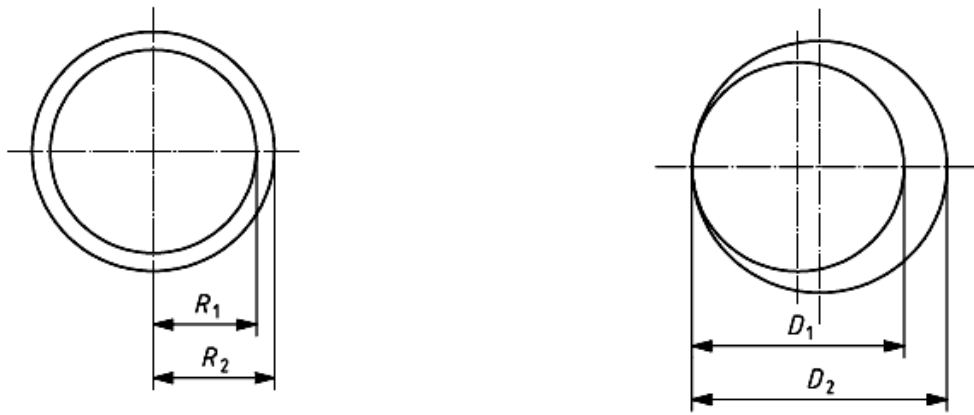

a) **Radial clearance**, $C_R = R_2 - R_1$

b) **Diametrical clearance**, $C_D = D_2 - D_1$

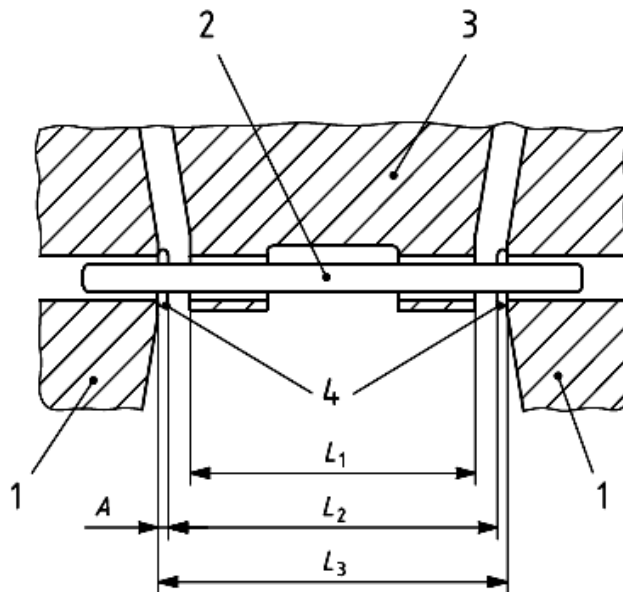

Key

- 1 valve body
- 2 pin
- 3 sealing assembly
- 4 bushings

c) **Total axial clearance**, C_{TA}

$$C_{TA} = L_2 - L_3; \text{ Clearance } A = (L_3 - L_2)/2$$

Figure 1 — Types of clearances

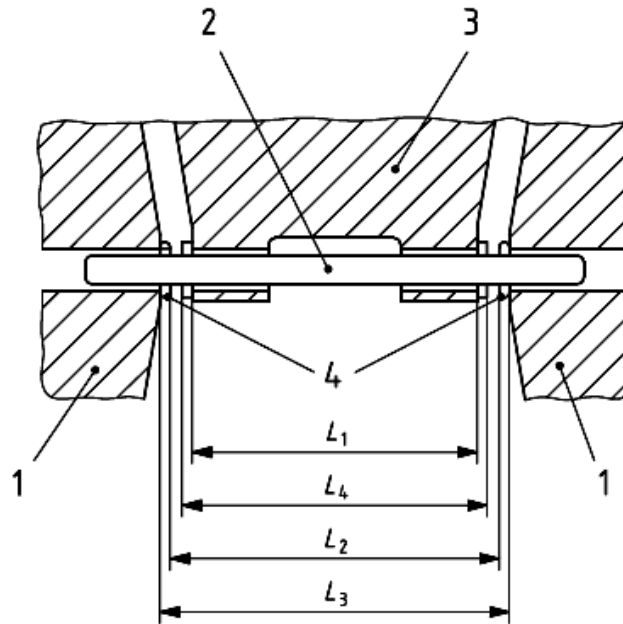
**Key**

- 1 valve body
- 2 pin
- 3 sealing assembly
- 4 bushings

d) Inside bushing dimensions

$$C_{TA} = (L_3 - L_2)/2 + (L_4 - L_1)/2$$

Figure 1 (Continued)**4.12 Hydraulic friction loss**

The maximum pressure loss across the valve at the appropriate flow given in Table 1, as tested by the method of 6.6, shall not exceed 0,08 MPa (0,8 bar). If the pressure loss exceeds 0,02 MPa (0,2 bar), the pressure loss shall be marked on the valve. See 7.3 j).

Table 1 — Required flow rates for pressure drop determination

Nominal size, mm	Flow rate, l/min
40	380
50	590
65	1000
80	1510
100	2360
125	3860
150	5300
200	9920
250	14720
300	21200

4.13 Endurance

The valve and its moving parts shall show no sign of distortion, cracks, loosening, separation or other sign of failure, following 30 min of water flow in accordance with 6.11.

4.14 Operational performance

4.14.1 A dry pipe valve with associated trim shall operate and provide an indication of operation at any service pressure within the ranges of 0,14 MPa (1,4 bar) to rated working pressure with the mechanical and/or electrical alarm devices pressurized to at least 0,05 MPa (0,5 bar), when tested in accordance with 6.11. The alarm devices shall sound for more than 50 % of the time for all flow conditions through a tripped valve.

4.14.2 A differential-type valve shall have a working differential within the range of 5:1 to 8,5:1 at 0,14 MPa (1,4 bar) service pressure and within the range of 5:1 to 6,5:1 at all higher service pressures, when tested in accordance with 6.11.

4.14.3 A mechanical-type dry pipe valve shall operate at an air pressure between 0,025 MPa (0,25 bar) and a fifth of the rated working pressure for all water pressures from 0,14 MPa (1,4 bar) to the rated working pressure, when tested in accordance with 6.11.

4.15 Drains

4.15.1 The valve shall be provided with a tapped opening to drain water from the valve body, when the valve is installed in any position specified or recommended by the manufacturer. The minimum opening size shall be 20 mm nominal.

4.15.2 Drain openings on valves shall be permitted to be used for draining the system pipework, when sized in conformance with applicable system installation standards.

4.15.3 Means shall be provided to automatically drain the piping between the valve, or any alarm shut-off valve, and the water motor alarm or water motor transmitter.

4.15.4 An intermediate chamber of a valve shall be provided with an automatic drain valve.

4.15.5 Flow or velocity-type drain valves shall close (i.e. substantially restrict flow) when tested in accordance with 6.11. Such valves shall remain closed during drainage of the system until pressure effective at the sealing mechanism becomes less than 0,03 MPa (0,3 bar) and shall open at a pressure between 0,0035 MPa (0,035 bar) and 0,03 MPa (0,3 bar).

4.15.6 The flow through an open end or velocity type drain valve shall not exceed 0,63 l/s at any service pressure up to the rated working pressure.

4.16 Alarms

4.16.1 A valve shall actuate its associated mechanical and electrical alarm devices at flow velocities through the valve up to 5 m/s, based on nominal pipe size, at inlet supply pressures of 0,14 MPa (1,4 bar) to the rated working pressure, when tested for operation in accordance with 6.11.

4.16.2 The valve shall provide at least a pressure of 0,05 MPa (0,5 bar) at its alarm port at a service pressure of 0,14 MPa (1,4 bar) while actuating relevant alarm devices, when tested in accordance with 6.10.

TCVN 6305-3: 2007

4.17 Valve impairment

4.17.1 While the valve is in the ready condition, it shall not be possible to interfere with the valve operating mechanism by external tampering.

4.17.2 A valve capable of being pressurized without its cover plate in place shall have some means of signaling a “cover off” condition.

5 Production testing and quality control

5.1 It shall be the responsibility of the manufacturer to implement and maintain a quality control program to ensure that his production continuously meets the requirements of this standard in the same manner as the originally tested samples.

5.2 Every manufactured valve shall pass a hydrostatic body test for a period not less than 1 min at twice the rated working pressure without leakage.

5.3 Following the hydrostatic body test in 5.2, every manufactured valve shall pass an operation test for correct functioning, including latching of the clapper upon tripping, if appropriate and flow from the alarm port.

5.4 Every manufactured valve shall withstand, without leakage at the valve seat, an internal hydrostatic pressure of twice the rated working pressure applied upstream of the clapper.

6 Tests

6.1 Samples

A representative sample of each size of valve shall be subjected to the following tests.

6.2 Spring and diaphragm test

Subject the spring or diaphragm in the normal mounting to 5 000 cycles of normal operation in air or water. The components shall not be operated at a rate exceeding 6 cycles per minute. For sealing assembly springs, the sealing assembly shall be rotated off the seat to a 45° angle and slowly return to the closed position. For internal bypass springs, the bypass shall be operated from the full open position to the closed position. Diaphragms shall be flexed from the normally open to the normally closed position.

6.3 Sealing element tests

6.3.1 Release test

With the valve in a normal working position and the sealing assembly in the closed position, a hydrostatic pressure of 0,35 MPa (3,5 bar) shall be applied to the outlet end of the valve for a period of 90 days. During this period, the water temperature shall be maintained at 87 ± 2 °C by an immersion heater or other suitable heating device. Provisions shall be made to maintain the water in the inlet end of the valve at atmospheric pressure.

Upon completion of this period of exposure, the water shall be drained from the valve and the valve shall be allowed to cool to ambient temperature for at least 24 h. With the outlet end of the valve at atmospheric pressure, a hydrostatic pressure of 0,035 MPa (3,5 bar) shall be gradually applied to the inlet end of the valve. The sealing assembly shall move off the seat and no piece of the seal other than colour shall adhere to the mating surface.

Where the same design of a seal is used for more than one size of valve, only a sample of the size with the highest stress on the seating surface shall be tested.

6.3.2 Non-reinforced elastomeric sealing element test

Prepare sixteen test specimens in accordance with ISO 37. Four samples shall be used to satisfy each of the following requirements:

- a) 4.10.2 a)
- b) 4.10.2 b) 1) or 4.10.2 b) 2);
- c) 4.10.2 c);
- d) 4.10.2 d).

6.3.3 Reinforced elastomeric sealing element test

The volume of eight reinforced elastomer sealing elements shall be measured. Each sample shall be uniquely identified. Four samples shall be exposed to an atmosphere of oxygen in accordance with ISO 188 at a pressure of 2 MPa (20 bar) for 96 h at 70 °C. The remaining four samples shall be submerged in boiling distilled water for 70 h. Following the exposure, the samples shall be allowed to cool to room temperature for at least 24 h. The volume of each shall be measured. Each sample shall then be bent

TCVN 6305-3: 2007

back upon itself by hand three times in the same direction around a rod having a diameter four to five times the material thickness.

6.4 Warm water ageing test for non-metallic components (excluding gaskets and seals)

Four untested samples of each component shall be immersed in tap water at $(87 \pm 2) ^\circ\text{C}$ for 180 days.

If a material cannot withstand the temperature indicated without excessive softening, distortion, or deterioration, a water ageing test shall be conducted at a lower temperature, but not less than $70 ^\circ\text{C}$, for a longer period of time. The duration of exposure shall be calculated from Equation (1):

$$t = 74857 e^{-0,069 3T} \quad (1)$$

where

t is the exposure duration, expressed in days;

e is the base of natural logarithms (= 2,7183);

T is the test temperature, expressed in degrees centigrade.

NOTE: This equation is based on the $10 ^\circ\text{C}$ rule, i.e. for every $10 ^\circ\text{C}$ rise, the rate of a chemical reaction is approximately doubled. When applied to plastic ageing, it is assumed that the life at a temperature, t, in $^\circ\text{C}$, is half the life at $(t - 10) ^\circ\text{C}$.

The samples shall be removed from the water and allowed to cool to room temperature for examination for a minimum of 24 h. The components shall be examined for cracking, warping, creep, or other signs of deterioration which would preclude the proper operation of the device. The parts are then to be assembled into valves and shall comply with the requirements of 4.8.1 and 4.14 when tested in accordance with 6.7 and 6.10.

6.5 Air ageing test for non-metallic components (excluding gaskets and seals)

Four untested samples of each component shall be aged in an air oven at $(120 \pm 2) ^\circ\text{C}$ for 180 days. The samples shall be tested in contact with the mating materials under stresses comparable to the intended use at rated working pressure. The components shall be supported so that they do not touch each other or the sides of the oven. If a material cannot withstand the temperature indicated without excessive softening, distortion or deterioration, a water aging test shall be conducted at a lower temperature, but not less than $70 ^\circ\text{C}$, for a longer period of time. The duration of exposure shall be calculated from Equation (2):

$$t = 737000 e^{-0,069 3T} \quad (2)$$

where

t is the exposure duration, expressed in days;

e is the base of natural logarithms (= 2,7183)

T is the test temperature, expressed in degrees centigrade.

NOTE: This equation is based on the 10 °C rule, i.e. for every 10 °C rise, the rate of a chemical reaction is approximately doubled. When applied to plastic ageing, it is assumed that the life at a temperature, t, in °C is half the life at (t – 10) °C.

The samples shall be removed from the oven and allowed to cool to room temperature for examination for a minimum of 24 h. The components shall be examined for cracking, warping, creep, or other signs of deterioration which would preclude the proper operation of the device. The parts are then to be assembled into valves and shall comply with the requirements of 4.8.1 and 4.14, when tested in accordance with 6.7 and 6.10.

6.6 Endurance test

Using the test apparatus, adjust the flow rate to the appropriate value given in Table 1, with a tolerance $^{+5}_0$ %. Sustain a water flow through the valve at this rate for (30^{+5}_0) min. Examine the valve for compliance with the requirements of 4.13.

6.7 Hydraulic friction loss test

Install the valve in a test apparatus using piping of the same nominal diameter (see 4.1). Use a differential pressure-measuring device accurate to ± 2 %.

Measure and record the differential pressure across the valve at a range of flows above and below the flows shown in Table 1. Replace the valve in the test apparatus by a section of pipe of the same nominal size and measure the differential pressure over the same range of flows. Using graphical methods, determine the pressure drops at the flows shown in Table 1. Record the hydraulic friction loss as the difference between the pressure drop across the valve and the pressure drop across the replacement pipe.

6.8 Valve leakage and deformation test

6.8.1 Body leakage test

TCVN 6305-3: 2007

Install the valve in a pressure test apparatus with the sealing assembly in the open position. Blank off all openings in the valve body. Apply hydrostatic pressure of twice the rated working pressure for a period of 5 min and inspect the valve during this time for signs of leakage. The valve shall conform to the requirements of 4.8.1.

6.8.2 Sealing assembly test (below to above sealing assembly)

With the sealing assembly in the closed position, prime the valve body when required by the manufacturer instructions. Apply air pressure at a rate not exceeding 0,14 MPa/min (1,4 bar/min) up to a pressure of 0,07 MPa (0,7 bar) above the trip point for the valve at its rated working pressure. Apply a hydrostatic pressure equal to the rated working pressure upstream of the sealing assembly and maintain this pressure for 2 h. During the application of hydrostatic pressure there shall not be leakage

- a) across the sealing assembly;
- b) into the intermediate chamber (differential type);
- c) into the alarm port (mechanical type).

The valves shall conform to the requirements of 4.8.2.

6.8.3 Sealing assembly test (mechanical type valves)

Fill the upstream end of the valve with water, while keeping the sealing assembly closed by the application of pressure on the appropriate devices and parts. Isolate these, if necessary, from the down stream end of the valve and keep this end vented.

Increase hydrostatic pressure to the upstream end from zero to twice rated working pressure at a rate not exceeding 0,14 MPa/min (1,4 bar/min). Maintain this pressure for 2 h. Examine for leakage, deformation and structural failure. The valve shall conform to the requirements of 4.8.3.

6.8.4 Leakage test for latched valves (above to below sealing assembly)

With the sealing assembly in the closed position, fill the valve body downstream of the sealing assembly with water. Apply hydrostatic pressure downstream of the sealing assembly at a rate not exceeding 0,14 MPa/min (1,4 bar/min) up to a pressure of twice the maximum manufacturers' specified installation air pressure. Maintain the hydrostatic pressure for 5 min. The valve shall conform to the requirements of 4.8.4.

6.8.5 Leakage test for unlatched valves (above to below sealing assembly)

With the sealing assembly in the closed position, fill the valve body downstream of the sealing assembly with water. Apply hydrostatic pressure downstream of the sealing assembly at a rate not exceeding 0,14 MPa/min (1,4 bar/min) up to a pressure of twice the rated working pressure. Maintain the hydrostatic pressure for 5 min. The valve shall conform to the requirements of 4.8.5.

6.9 Body strength test

For the purpose of this test, standard production bolts, gaskets and seals may be replaced by components capable of withstanding the test pressure. The valve inlet and outlet connections and all other openings shall be suitably blanked off or plugged.

There shall be a connection for hydrostatically pressurizing the assembled sample valve at the inlet connection and a means of venting air and pressurizing fluid at the outlet connection. With the sealing assembly blocked open, the sample valve assembly shall be internally hydrostatically pressurized at four times the rated working pressure, but not less than 4,8 MPa (48 bar), for a period of 5 min. The sample valve shall be assessed in accordance with 4.5.1.

6.10 Fire exposure test

Mount the valve horizontally with body openings sealed as shown in Figure 2. Open shut-off valves A and B. Fill the pipework and valve with water. Open the test valve to vent all air.

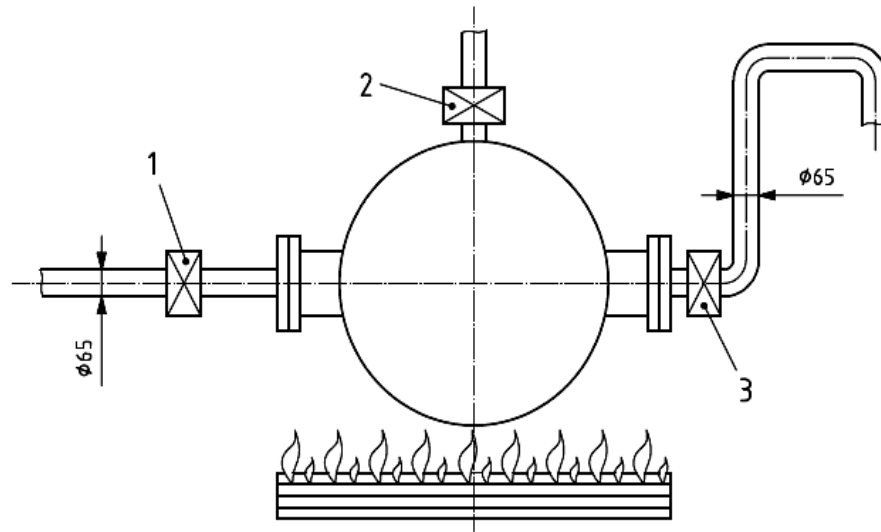
**Key**

- 1 shut-off valve A
- 2 test valve
- 3 shut-off valve B

Figure 2 — Fire test installation

Close valve A and valve B.

Position a fire tray, having a surface area not less than 1 m², centrally beneath the sample valve. Place a sufficient volume of a suitable fuel in the tray to give an average air temperature between 800 °C and 900 °C around the valve for a period of 15 min after a temperature of 800 °C is reached.

Measure the temperature with a thermocouple positioned 10 mm from the surface of the sample valve on a horizontal plane parallel to the axis at the midpoint between the mounting connections.

CAUTION — Ensure the test valve remains open to atmosphere while testing to permit venting of any pressure build-up.

Ignite the fuel and, 15 min after 800 °C is attained, remove the fire tray or extinguish the fire. Starting within 1 min of extinguishment, or removal of the tray, cool the sample valve by flowing 100 l/min of water through the pipework for 1 min. Test the sample valve with an internal hydrostatic pressure by the method of 6.8.1. Gaskets and seals may be replaced for this hydrostatic test. The valve shall conform to the requirements of 4.4.2.

6.11 Operational test

6.11.1 General

Subject the valve to a series of operational tests at water service pressures of 0,04 MPa (0,4 bar), 0,14 MPa (1,4 bar) and from 0,2 MPa (2 bar) to the rated working pressure in increments of 0,1 MPa (1 bar), using the test installation shown in Figure 3.

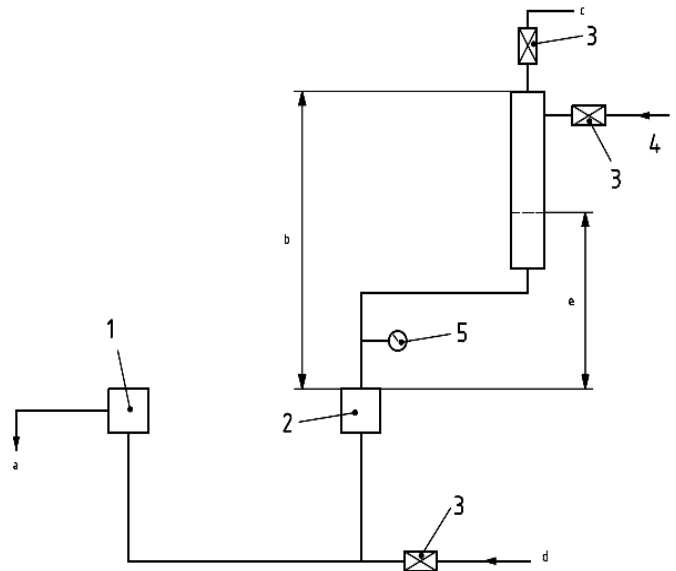

Key

- 1 150 mm quick-opening valve
- 2 dry pipe valve under test
- 3 shut-off valve
- 4 water reservoir
- 5 pressure gauge

NOTE: Remove all air from piping between quick-opening device and inlet side of dry pipe valve prior to each test.

^a To atmosphere.

^b Supply of 1,9 m³ capacity.

^c Air.

^d Water (typical).

^e Water capacity (see Table 1).

Figure 3 — Installation for operational and anti-reseating tests

6.11.2 Dry pipe valve installation

Before each test, clean sealing assembly seats and seat rings and all other operating parts. Seat the main sealing assembly member properly and, when applicable, place the lever mechanism in the set position. Bolt the cover plate in place. Establish the priming water level and system air pressure in accordance with the manufacturer's requirements. Then fully open the main water supply valve, check for leakage into the alarm port.

Install the dry pipe valve in the test apparatus generally depicted by Figure 3.

Fully open the main water supply valve, check for leakage into the alarm port and trip the dry pipe valve under normal operating conditions.

Record the following pressures:

- a) water supply;
- b) initial system air;
- c) valve leak point;
- d) valve trip point;
- e) alarm port.

Record the position of the valve sealing assembly with relation to any anti-reseat latching mechanism, if provided, after each operation.

Compute and record the differential of a differential-type dry pipe valve from the data and check for compliance with 4.14.2. For mechanical type valves, record air and service pressures and check for compliance with 4.14.3.

6.12 Anti-reseating test (see 4.7.7)

6.12.1 Install a valve in the system piping in its normal installation position. Install a second valve of the quick-opening type of 150 mm nominal size as shown in Figure 3, with a discharge to atmosphere through 150 mm diameter piping. Connect the outlet of the test valve to a reservoir with a volume of at least 1,9 m³ using piping with diameter not less than the test valve size.

6.12.2 Set the sealing assembly of the test valve in the open position, with the sealing assembly on the lowest latch, and where appropriate refit the cover plate. Fill the system and test valve, exclusive of the 1,9 m³ reservoir volume, fully with water. Fill the reservoir with air and water in accordance with one set of the values shown in Table 2. Close the supply valve and trip the quick-opening valve causing flow past the test valve sealing assembly.

CAUTION — Make sure that the reservoir is fully depressurized before examining the test valve.

6.12.3 Repeat the test at each set of values given in Table 2.

Table 2 — Reservoir conditions

Service pressure, bar	Water percentage of reservoir volume, %
7	45
10	30
10	15
12	25

6.12.4 Inspect the sealing assembly to determine that it has not returned to its ready position, nor sustained any distortion, cracks, separation or other signs of failure.

6.12.5 Following this test, the valve shall comply with the requirements of 4.14 at a service pressure of 0,14 MPa (1,4 bar), when tested on time in accordance with 6.10. The test may be stopped when all of the water has passed the valve under test.

6.13 Quick release

6.13.1 Set the test apparatus to give a volume of 1,5 m³ upstream of the valve. Provide priming water if recommended by the manufacturer. Trip the valve using twice the maximum recommended air pressure, but not less than 0,69 MPa (6,9 bar) downstream and upstream of the sealing assembly. Trip the test valve by rapidly releasing the air pressure downstream of the sealing assembly through a 50 mm valve.

TCVN 6305-3: 2007

6.13.2 Inspect the sealing assembly and valve to determine that they have not sustained any distortion, cracks, separation or other signs of failure.

6.13.3 Verify the valve function in accordance with 6.10 and check for compliance with 4.7.8.

6.14 Salt mist corrosion test

6.14.1 Reagents

Sodium chloride solution, consisting of (20 ± 1) % (m/m) sodium chloride in distilled water, pH between 6,5 and 7,2 and having a density between 1,126 g/ml and 1,157 g/ml at (35 ± 2) °C.

6.14.2 Apparatus

Fog chamber, of minimum volume 0,43 m³, fitted with a recirculating reservoir and aspirating nozzles to deliver a salt spray, and means for sampling and controlling the atmosphere in the chamber.

6.14.3 Procedure

Remove the cover (if fitted) from the alarm valve. Support the alarm valve and alarm valve cover in the fog chamber in such a way that solution does not collect in any cavities and expose them to a salt spray by supplying the sodium chloride solution through the nozzles at a pressure of between 0,07 MPa (0,7 bar) and 0,17 MPa (1,7 bar), while maintaining the temperature in the exposure zone at (35 ± 2) °C. Ensure that solution running off the component parts under test is collected and not returned to the reservoir for recirculation.

NOTE: The cover can be omitted from the test if none of the sealing assembly bushings, bearings or their clearances are associated with the cover.

Collect salt mist from at least two points in the exposure zone and measure the rate of application and the salt concentration. Ensure, for each 80 cm² of the collection area, at a collection rate of 1 ml/h to 2 ml/h over a period of $(16^{+0,25}_0)$

Expose the component parts for a period of $(10^{+0,25}_0)$ days. After exposure, remove the alarm valve and cover (if under test) from the fog chamber and allow to dry for $(7^{+0,25}_0)$ days at a temperature not exceeding 35 °C and at a relative humidity not greater than 70 %. After the drying period, examine the corrosion protected steel parts for visible signs of deterioration of the coating such as blistering, delamination, flaking or increased resistance to movement.

7 Marking

7.1 Dry pipe valves shall be marked either directly on the body with raised or depressed cast letters or on a permanent metal label attached mechanically (such as with rivets or screws). Cast metal labels shall be nonferrous.

7.2 Cast body markings shall be in letters and figures at least 9,5 mm high. The height of the marking may be reduced to 5 mm for 50 mm and smaller valves. Cast body letters and figures shall be raised or depressed by at least 0,75 mm.

Cast label markings shall be at least 5 mm high and raised or depressed by 0,5 mm. Letters on an etched or stamped permanent label shall be a minimum of 5 mm high and 0,1 mm deep. Serial number or year of manufacture shall be stamped in letters and figures at least 3 mm high.

7.3 Dry pipe valves shall be marked with the following:

- a) name or trade mark of the manufacturer or vendor;
- b) distinctive model number, catalogue designation or an equivalent marking;
- c) name of the device, such as “dry pipe valve”;
- d) indication of flow direction;
- e) nominal size;
- f) maximum working pressure in MPa (or bar). If inlet and/or outlet connections are machined for lower working pressures as in 4.3.2, the lower pressure limit shall be marked.
- g) serial number or year of manufacturer. Valves produced in the last three months of a calendar year may be marked with the following year as the date of manufacture; valves produced in the first six months of a calendar year may be marked with the previous year as the date of manufacture;
- h) mounting position, if limited to vertical or horizontal position;
- i) factory of origin, if manufactured at two or more factories;
- j) pressure loss, if required (see 4.12).

8 Instruction charts and trim

8.1 A copy of the instruction chart shall be supplied with each dry pipe valve. The chart shall include an illustration showing the valve trim function, cross-section assembly views to explain the valve operation, and friction loss value if in excess of 0,02 MPa (0,2 bar).

8.2 The instruction chart shall include recommendations for care and maintenance and shall detail the method for setting the valve.

Bibliography

[1] TCVN 6101 (ISO 6183) Fire protection equipment — Carbon dioxide extinguishing systems for use on premises. Design and installation

[2] TCVN 6553 (ISO 6184) (all parts), Explosion protection systems.
